



Code: PRO 910 080 03
PERFORMANCE SERIAL. 9 PISTONS PUMP
80 LT. TYP PRO 910

PRO **DECODING**
910 080 03

PUMP TYPE

ROTATION

DISPLACEMENT



PISTON PUMPS

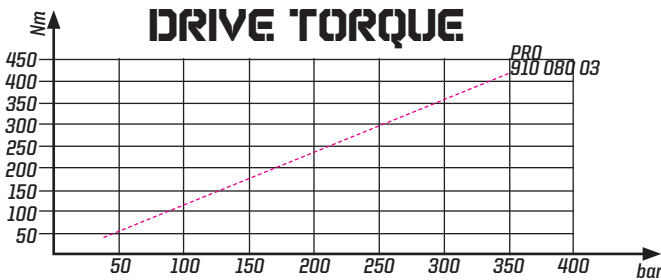
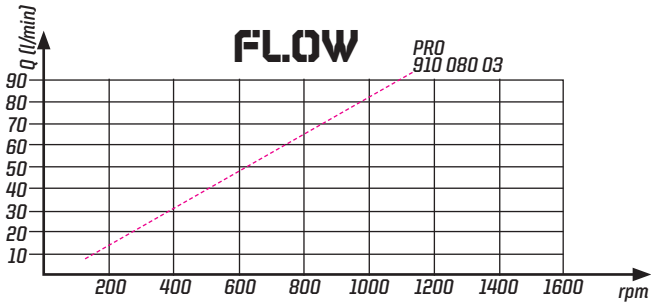

Fluid Temp. °C	Input Pres. Bar	Optimale K. Viscosity	Oil Filtering
0 / 90	0,3 / 2 bar	10 / 100 cST	> 200 bar : 25 um < 200 bar : 35 um



BIDIRECTIONAL PUMP

USED PLACED :
DUMPER TRUCKS
PRIVATE AIM WINCHES
TRACTOR LADLES

NOTE : THE ABOVE SPECIFICATIONS REFER TO OIL TYPE ISO VG 46 AT 50°



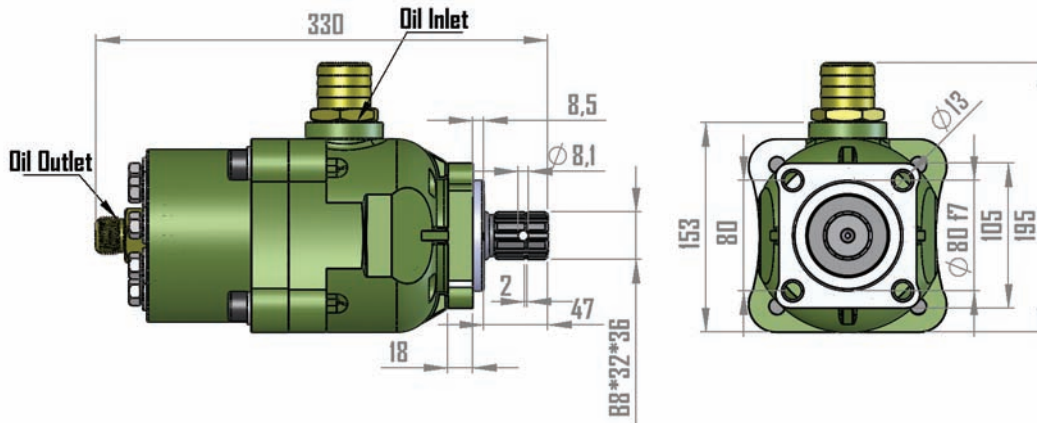





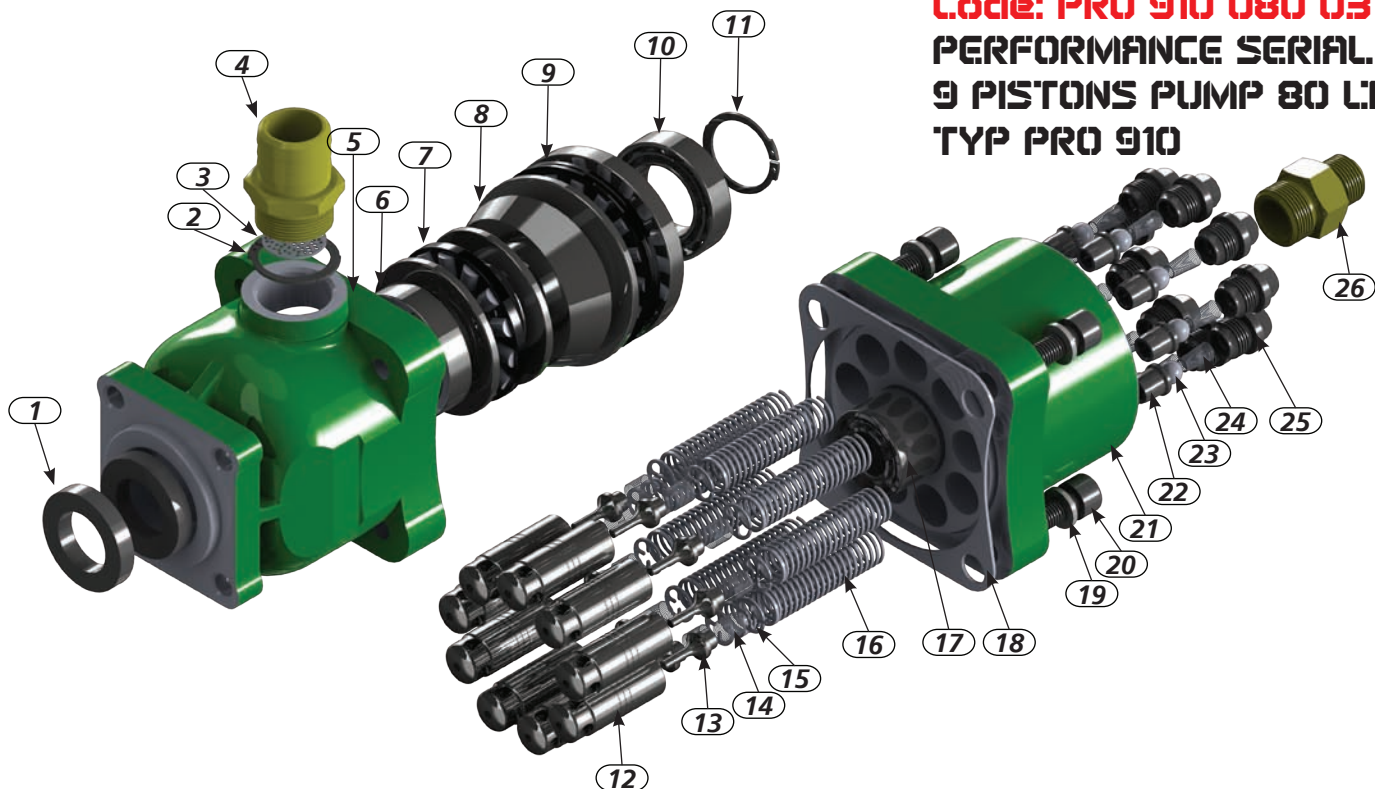



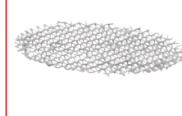







NOTE : TAKE A CONSIDERATION THAT OIL INLET TUBE CONNECTOR MUST BE VERTICAL POSSITION & THE PUMP MUST BE 100 mm DISTANCE TO THE OIL TANK DURING TO ASSEMBLY. BEFORE STARTING THE PUMP BLEED THE AIR.



Code	Displacement cm ³ /1000	Rotation	Test Pressure 1	Test Pressure 2	Max. Test Pressure	Oil Inlet	Oil Outlet	Max. Con. Speed Rpm	Max. Inter. Speed Rpm	Weight
PRO 910 080 03	81,5	Double	300	320	340	6 1" 1/4"	6 1"	1800	2000	18,5
Test Pressure 1 : 60 sec.			Test Pressure 2 : 18 sec. Max.			Max Test Pressure : 8 sec. Max.				

Code: PRO 910 080 03
PERFORMANCE SERIAL
9 PISTONS PUMP 80 LT.
TYP PRO 910



<p>Pos: 1 Qty: 2</p>  <p>Code: 020 040 401 Seal Mim 35*58*10</p>	<p>Pos: 2 Qty: 1</p>  <p>Code: 020 010 235 Circlip 472/35</p>	<p>Pos: 3 Qty: 1</p>  <p>Code: 020 090 027 Filter 1*1</p>	<p>Pos: 4 Qty: 1</p>  <p>Code: 020 110 007 Nipple 1" 1/4</p>	<p>Pos: 5 Qty: 1</p>  <p>Code: 020 080 101 Cover</p>	<p>Pos: 6 Qty: 1</p>  <p>Code: 020 020 806 Bearing 6207</p>	<p>Pos: 7 Qty: 1</p>  <p>Code: 020 020 706 Bearing 81211</p>
<p>Pos: 8 Qty: 1</p>  <p>Code: 020 080 066 Crank Shaft</p>	<p>Pos: 9 Qty: 1</p>  <p>Code: 020 020 707 Bearing 81214</p>	<p>Pos: 10 Qty: 1</p>  <p>Code: 020 020 802 Bearing 6008</p>	<p>Pos: 11 Qty: 1</p>  <p>Code: 020 010 140 Circlip 471/40</p>	<p>Pos: 12 Qty: 9</p>  <p>Code: 020 090 064 Piston</p>	<p>Pos: 13 Qty: 9</p>  <p>Code: 020 090 065 Piston Valve</p>	<p>Pos: 14 Qty: 9</p>  <p>Code: 020 005 018 Sipring</p>
<p>Pos: 15 Qty: 9</p>  <p>Code: 020 010 159 Circlip 40</p>	<p>Pos: 16 Qty: 9</p>  <p>Code: 020 005 017 Spring</p>	<p>Pos: 17 Qty: 1</p>  <p>Code: 020 020 501 Bearing 3205</p>	<p>Pos: 18 Qty: 1</p>  <p>Code: 020 050 104 Seal</p>	<p>Pos: 19 Qty: 4</p>  <p>Code: 020 100 031 Washer M 14</p>	<p>Pos: 20 Qty: 4</p>  <p>Code: 020 100 001 Screw M 14*45</p>	<p>Pos: 21 Qty: 1</p>  <p>Code: 020 080 078 Body</p>
<p>Pos: 22 Qty: 9</p>  <p>Code: 020 090 062 Ring</p>	<p>Pos: 23 Qty: 9</p>  <p>Code: 020 020 101 Ball 1/2"</p>	<p>Pos: 24 Qty: 9</p>  <p>Code: 020 005 004 Sipring</p>	<p>Pos: 25 Qty: 9</p>  <p>Code: 020 090 066 Plug M 22*1,5</p>	<p>Pos: 26 Qty: 1</p>  <p>Code: 020 110 006 Nipple 1"R 1*1/16</p>		

www.steelcom.com